



METRA
BUILDING



SYSTEMS

Porte interne e pareti divisorie
Internal doors and partition walls





Indice

Index

Le nostre linee

Our product lines

Il nostro ecosistema	<i>Our ecosystem</i>	p. 03
8 buone ragioni	<i>8 good reasons</i>	p. 04
Ecosostenibilità	<i>Eco-sustainability</i>	p. 08
Porte interne e pareti divisorie	<i>Internal doors and partition walls</i>	
• Le nostre linee	• <i>Our product lines</i>	p. 12
• Tipologie di aperture	• <i>Opening typologies</i>	p. 14
Le linee	<i>The product lines</i>	
• Linea Sormonto	• <i>Overlap typology line</i>	p. 16
• Linea Complanare	• <i>Coplanar typology line</i>	p. 20
• Linea Scorrevoli a incasso	• <i>Sliding typology line</i>	p. 24
• Linea Cardini a scomparsa	• <i>With hidden pivot line</i>	p. 28
• Linea Pareti divisorie	• <i>Partition walls line</i>	p. 32
Tecnologia	<i>Technology</i>	p. 36



Il nostro ecosistema

Our ecosystem

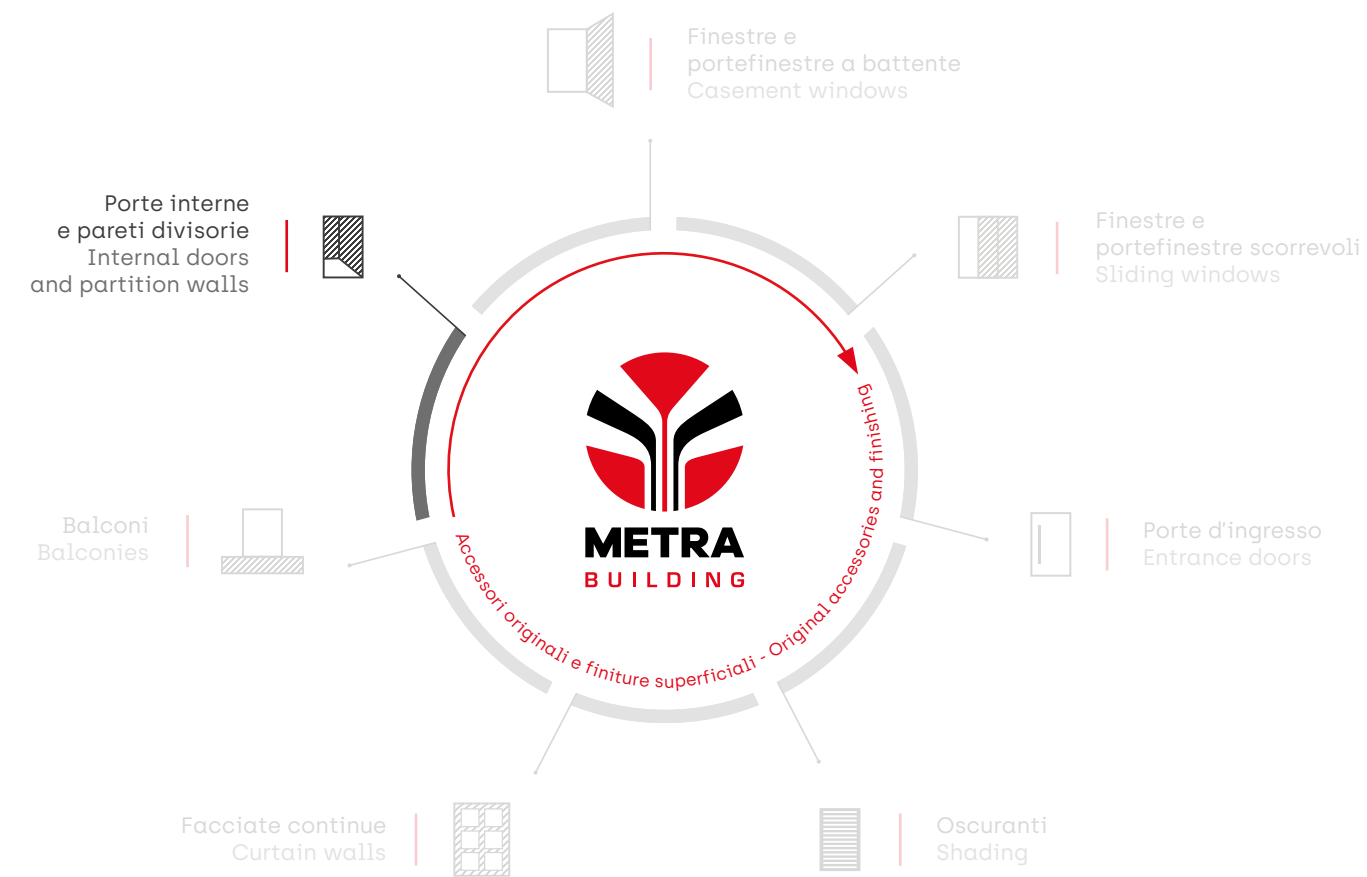

Qualità certificata
Certified quality





Serramenti in alluminio METRA Building: 8 buone ragioni

METRA Building Aluminium windows and doors: 8 good reasons

Essenziale e luminoso Essential and bright

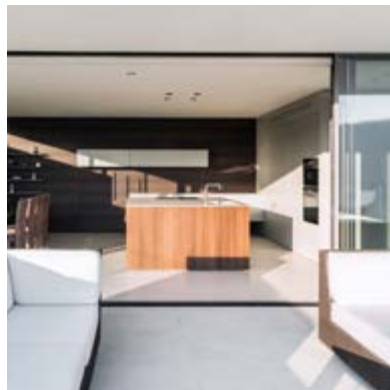

Geometrie compatte che consentono di recuperare luminosità negli spazi. La tecnologia giunge ai suoi massimi livelli e si condensa fino a soli 63 mm di spessore. La bellezza si traduce in design e si completa con accessori a scomparsa e maniglie minimali.

Compact geometries that allow to recover brightness in spaces. The technology reaches its maximum level and condenses to a thickness of only 63 mm. Beauty translates into design and is completed with concealed accessories and minimalist handles.

Praticamente eterni Practically eternal

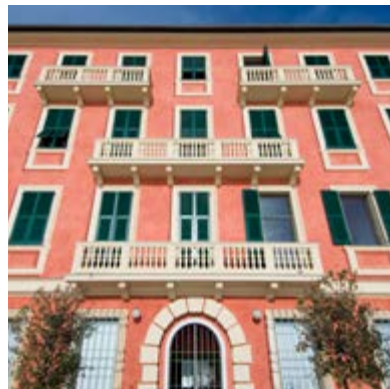

Resistenza meccanica, stabilità, robustezza e manutenzione ridotta ai minimi termini. Numerose qualità e straordinari vantaggi in un unico materiale in grado di durare per sempre.

Mechanical resistance, stability, robustness and maintenance reduced at the minimum. Numerous qualities and extraordinary advantages in a single material able to last forever.

Isolamento termico e acustico da classe Gold Gold class thermal and acoustic insulation



Con la tecnologia HES (High Energy Saving) l'isolamento termico è ai massimi livelli prestazionali. La riduzione dei costi energetici nel riscaldamento e raffreddamento è assicurata, così come il comfort abitativo reso ancor più elevato dal perfetto isolamento acustico.

With HES (High Energy Saving) technology thermal insulation is at the highest performance levels. The reduction of energy costs in heating and cooling is ensured, as well as the living comfort made even higher by perfect sound insulation.

Sonni tranquilli Sleep soundly



Sicurezza garantita con i sistemi antieffrazione in classe RC2 e RC3. un sistema di chiusura perimetrale fino a 16 punti (predisposizione antifurto) capace di resistere a scassinatori e malintenzionati.

Guaranteed security with class RC2 and RC3 burglar-proof systems. a perimeter locking system with up to 16 points (anti-theft predisposition) able to resist burglars and malicious intruders.



Tutti i colori della performance

All colours of performance



Spazio alla fantasia nella scelta dei colori. Finiture ossidate, verniciature opache, lucide, extralucide e trattamenti effetto legno a marchio Qualanod-Qualicoat-Seaside-Qualideco anche con opzione antibatterica. Durata assicurata fino a 30 anni.

Space for imagination in the choice of colours. Oxidised finishes, matt, gloss, high-gloss and wood-effect treatments under the Qualanod-Qualicoat-Seaside-Qualideco brand also with antibacterial option. Guaranteed durability up to 30 years.

Più spazio al movimento

More space for movement



Estetica e accessibilità in un unico sistema che abbatte le barriere architettoniche e consente facili accessi. Con la soglia ribassata gli ostacoli si riducono al minimo.

Aesthetics and accessibility in a single system that breaks down architectural barriers and allows easy access. With the lowered threshold, obstacles are reduced to a minimum.

Sistema integrato perfetto

Perfect integrated system

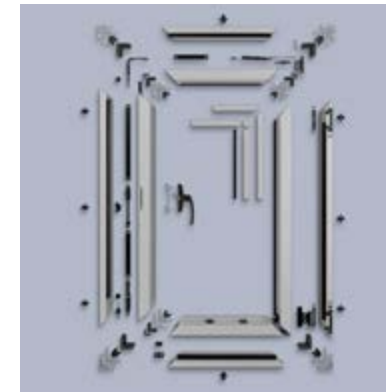

Maniglie, meccanismi di apertura e chiusura, cerniere, guarnizioni e squadrette: tutti gli accessori coordinati, rigorosamente originali METRA Building, si fondono con il serramento per garantire i migliori risultati.

Handles, opening and closing devices, hinges, gaskets and corner cleats: all matching accessories, rigorously METRA Building original, blend with the window or door to guarantee the best results.

Eccellenza italiana

Italian excellence



Tutti i serramenti METRA Building sono estrusi in Italia e rispondono alle più selettive certificazioni internazionali. I migliori processi produttivi integrati, uniti a oltre 60 anni di know-how, per creare un prodotto bello, sicuro e dalle prestazioni inimitabili.

All METRA Building windows and doors are extruded in Italy and meet the most selective international certifications. The best integrated production processes, combined with over 60 years of know-how, to create a beautiful and safe product with inimitable performance.

I nostri profili in alluminio sono presenti in alcune delle più prestigiose realizzazioni al mondo: dalla iconica Piramide del Louvre, alle torri di New York fino agli avveniristici grattacieli di Dubai.

Our aluminium profiles are featured in some of the most prestigious projects in the world: from the iconic Louvre Pyramid to the towers of New York and the futuristic skyscrapers of Dubai.



Ecosostenibilità Eco-sustainability

L'alluminio è una scelta sostenibile per gli edifici: ha un'elevata durabilità, ridotta manutenzione e può essere riciclato al 100% e all'infinito, senza perdere le sue proprietà.

L'attenzione per la riduzione dell'impatto ambientale di Metra riguarda tutta la catena del valore dell'alluminio, grazie all'elevato contenuto di materiale riciclato nei profili e l'assenza di VOC, che si concretizza nelle certificazioni ambientali (EPD) ottenute sui prodotti.

Metra Building mette a disposizione un portafoglio di soluzioni per garantire una progettazione sostenibile a basso impatto ambientale, che garantiscono efficienza energetica e favoriscono l'utilizzo della luce naturale, in linea con i requisiti dei protocolli LEED, BREEAM, DGNB e il rispetto dei Criteri Ambientali Minimi.

Aluminium is a sustainable choice for buildings: it has high durability, low maintenance and can be recycled 100% and infinitely without losing its properties.

The attention to reducing Metra's environmental impact concerns the entire aluminium value chain, thanks to the high content of recycled material in the profiles and the absence of VOCs, which is reflected in the environmental certifications (EPD) obtained on the products.

Metra Building offers a portfolio of solutions to guarantee sustainable design with low environmental impact, which guarantee energy efficiency and support the use of natural light, in line with the requirements of LEED, BREEAM, DGNB protocols and compliance with Minimum Environmental Criteria.

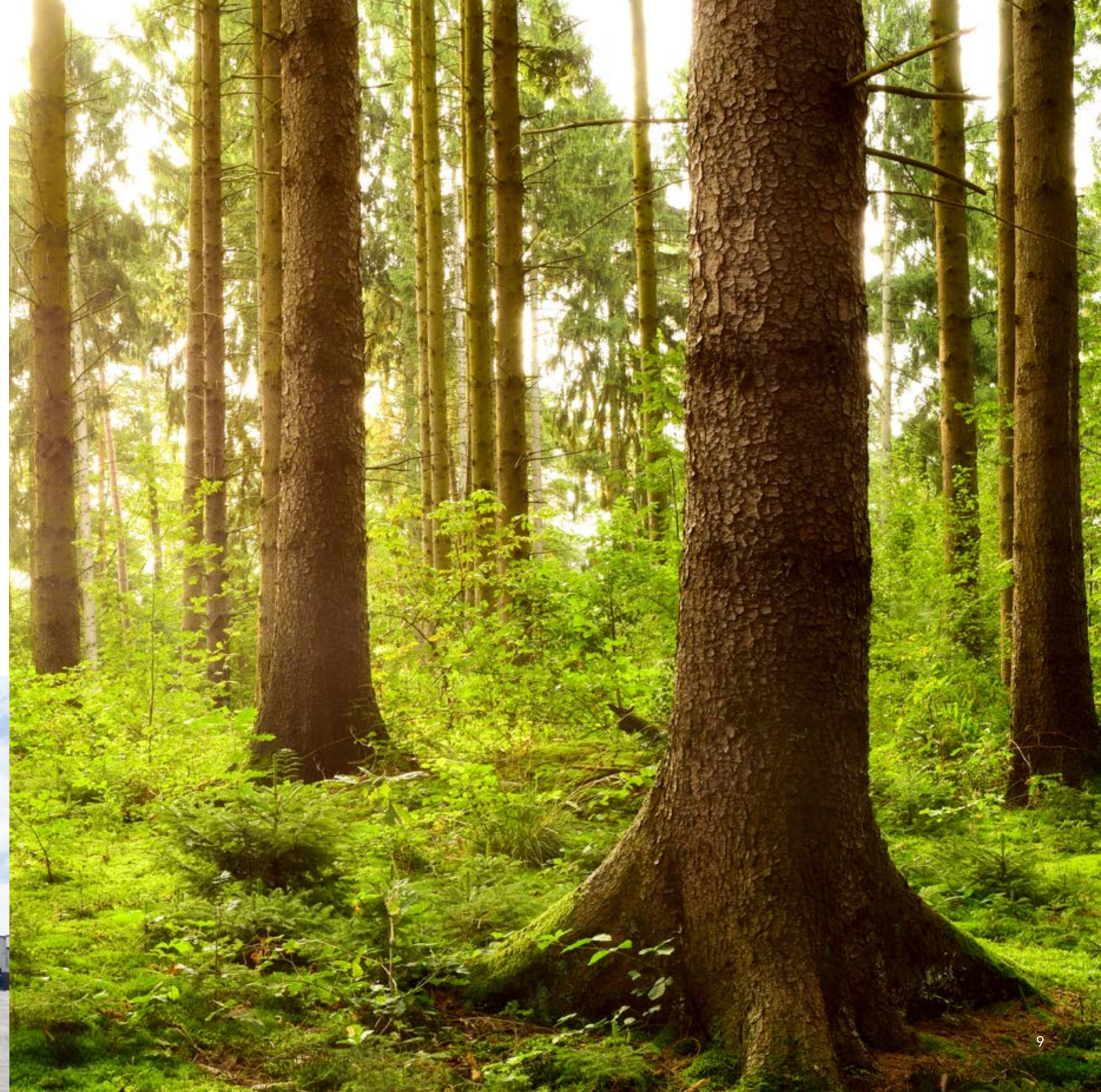



Porte interne e pareti divisorie

Internal doors and partition walls





Le nostre linee

Our product lines

Porte interne - Internal doors



Linea Sormonto
Overlap typology line



Linea Complanare
Coplanar typology line



Linea Scorrevoli a incasso
Pocket doors line



Linea Cardini a scomparsa
With hidden pivot line

Pareti divisorie - Partition walls



Linea Pareti divisorie
Partition walls line





Tipologie di aperture

Opening typologies

Porte interne Internal doors



1 anta battente
1 leaf door

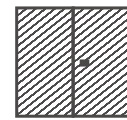

2 ante battente
2 leaf door



Scorrevoli ad incasso
nella muratura
Sliding into the wall



Scorrevoli sulla muratura
esterna
Sliding outside along the wall

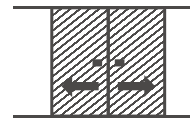

2 ante scorrevoli sulla muratura
esterna
2 sliding outside along the wall

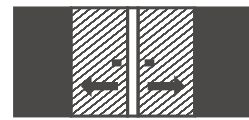

2 ante scorrevoli ad incasso
nella muratura
2 sash sliding into the wall

Pareti divisorie Partition walls

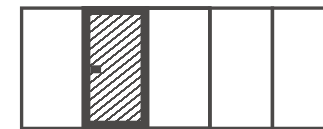

Apribile a battente
con cornice
Framed casement solution

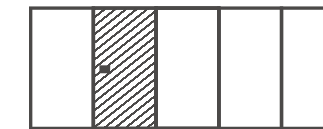

Apribile a battente vetrato
Glazed casement solution



Soluzione porta interna
Internal door solution

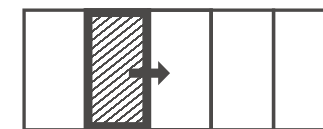

Apribile scorrevole con
cornice
Framed sliding solution

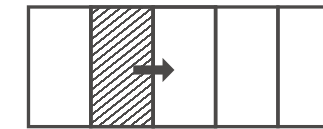

Apribile scorrevole vetrato
Glazed sliding solution



Specchiature fisse
Fixed lights

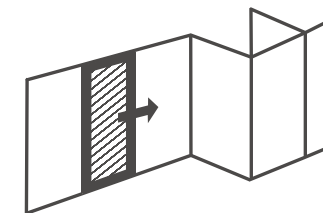

Soluzioni ad angolo
Corner solutions



Porte interne
Internal doors

Linea Sormonto
Overlap typology line



Porte interne
Internal doors

Linea Sormonto
Overlap typology line

SORMONTO | OVERLAP TYPOLOGY

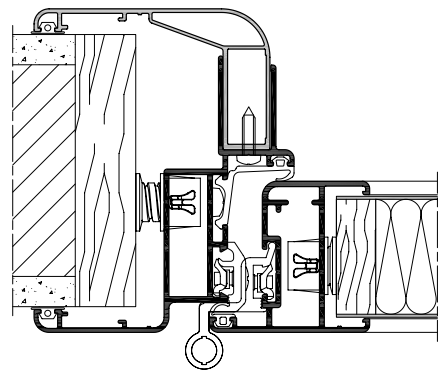

Porte con anta a sormonto con doppia guarnizione di battuta, realizzabili con pannello e/o vetro:

- Anta da 53 mm con serratura montata sul pannello
- Anta da 86 mm con serratura montata direttamente sul montante

Doors with overlap casement with double rabbet gasket, with panel and/or glass:

- *53 mm casement with lock fitted onto the panel*
- *86 mm casement with lock fitted onto the jamb*





Porte interne
Internal doors

Linea Complanare
Coplanar typology line



Porte interne
Internal doors

Linea Complanare
Coplanar typology line

COMPLANARE | COPLANAR TYPOLOGY

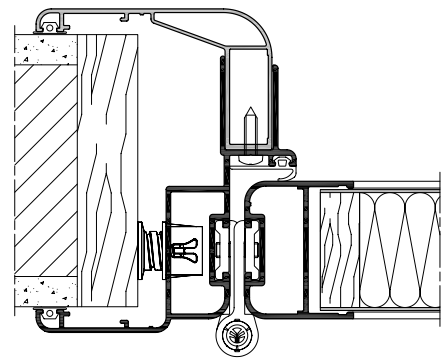

Porta con anta raggiata e complanare con il telaio, realizzabili con pannello e/o vetro. Varianti costruttive:

- Tutto pannello
- Pannello rifinito con cornice di alluminio
- Ante da 36/68/92 mm



Doors with rounded casement, coplanar with the frame, with panel and/or glass.

Versions:

- *Full panel*
- *Panel with aluminium frame*
- *36/68/92 mm casement*





Porte interne
Internal doors

Linea Scorrevoli a incasso
Pocket door line



Porte interne
Internal doors

Linea Scorrevoli a incasso
Pocket door line

SCORREVOLE INCASSO | POCKET DOOR

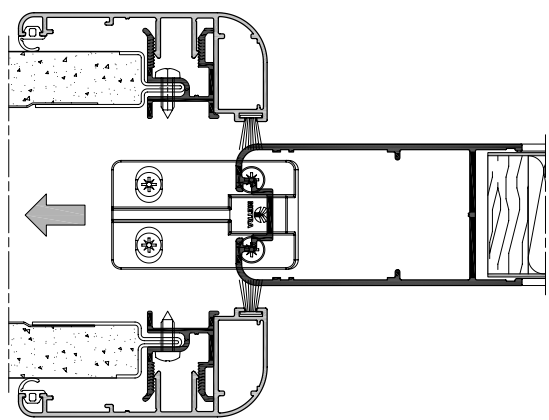

Porte con anta scorrevole ad incasso nella muratura, realizzabili con pannello e/o vetro:

- Anta da 36 mm con serratura montata sul pannello
- Anta da 92 mm con serratura montata direttamente sul montante
- Guarnizioni elastiche di sicurezza, inserite nei profilati compensatori



Pocket doors sliding into the wall with panel and/or glass:

- 36 sash mm with lock fitted onto the panel
- 92 mm sash with lock fitted onto the jamb
- Elastic safety gaskets, inserted into the compensation profiles





Porte interne
Internal doors

Linea Cardini a scomparsa
With hidden pivot line



Porte interne
Internal doors

Linea Cardini a scomparsa
With hidden pivot line

CARDINI A SCOMPARSA | GLAZED TYPOLOGY WITH HIDDEN PIVOT

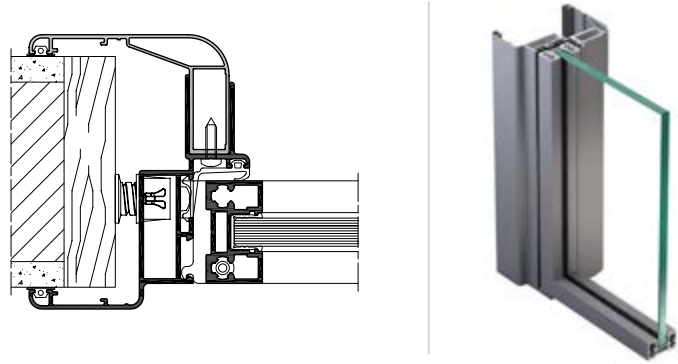

Porte con anta a sezione ridotta, realizzabili con vetro:

- Anta da 22 mm con vetro ad infilare da 11 mm di spessore
- Apertura mediante cardini a scomparsa

Doors with casement with reduced section, with glass:

- 22 mm casement with 11 mm glass fitted by insertion
- Opening by hidden pivots

CARDINI A SCOMPARSA - GLASS PARTITION | GLAZED TYPOLOGY WITH HIDDEN PIVOT - GLASS PARTITION

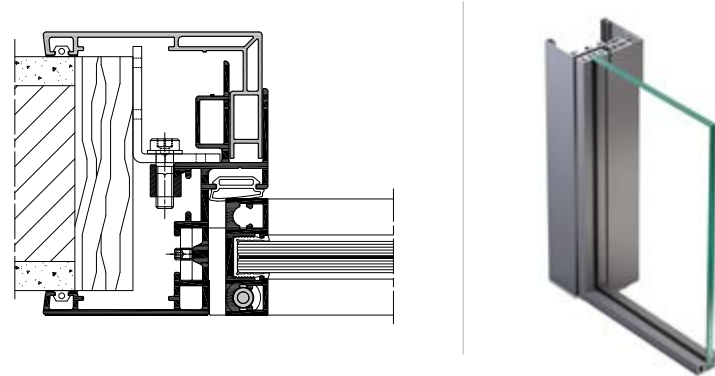

Porte con anta a scomparsa, realizzabili con vetro:

- Anta da 14.5 mm con vetro ad infilare da 10mm o 12mm di spessore
- Apertura mediante cardini a scomparsa

Doors with hidden casement:

- 14,5 mm casement with 10 or 12 mm glass fitted by insertion
- Opening by hidden pivots





Pareti divisorie
Partition walls

Linea Pareti divisorie
Partition walls line



Pareti divisorie
Partition walls

GLASS PARTITION | GLASS PARTITION

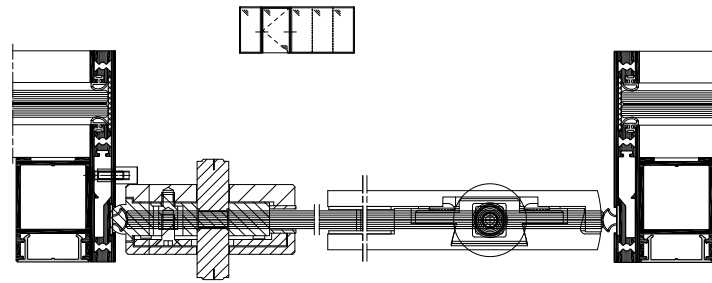

Dimensioni base del sistema:

- Montanti: 50 mm
- Traversi: 50 mm
- Spessore dei vetri: da 10 o 12 mm
- Guarnizioni di tenuta vetro: PVC o silicone trasparenti



Base dimensions:

- Jamb: 50 mm
- Transoms: 50 mm
- Glass thickness: from 10 or 12 mm
- Glazing gaskets: PVC or transparent silicone





Tecnologia

Technology

Porte interne - Internal doors

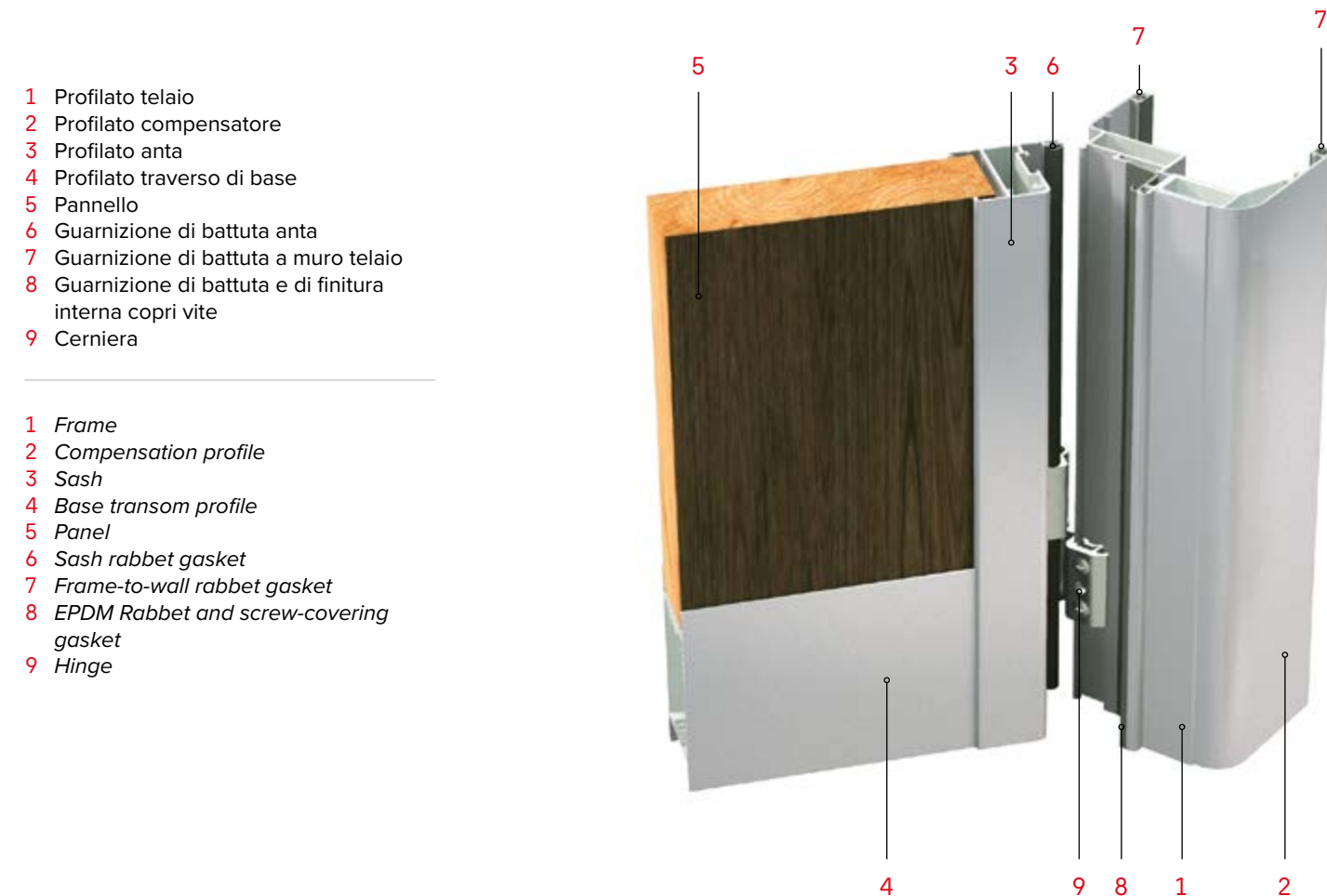

Tecnologia

Technology

Pareti divisorie - Partition walls

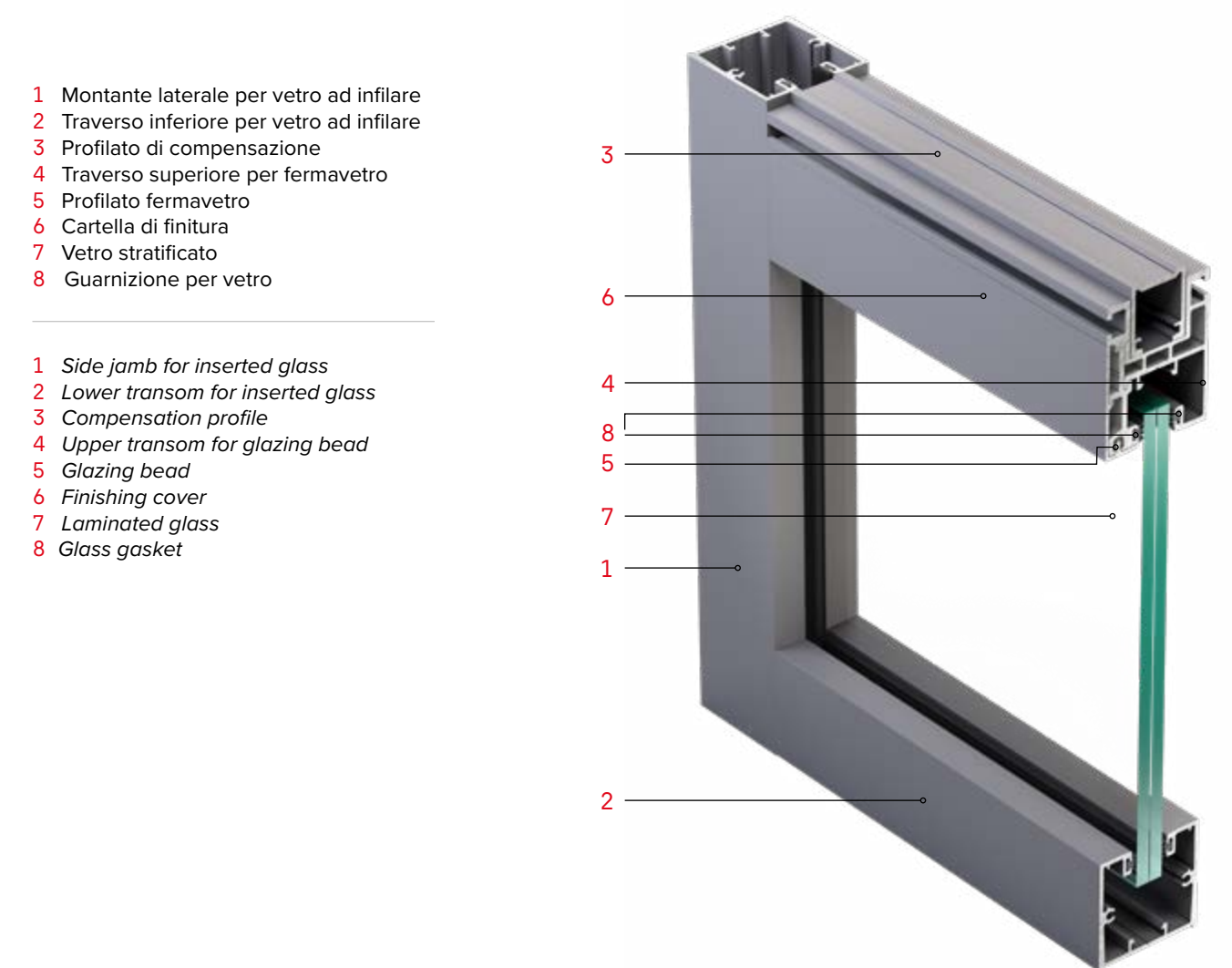

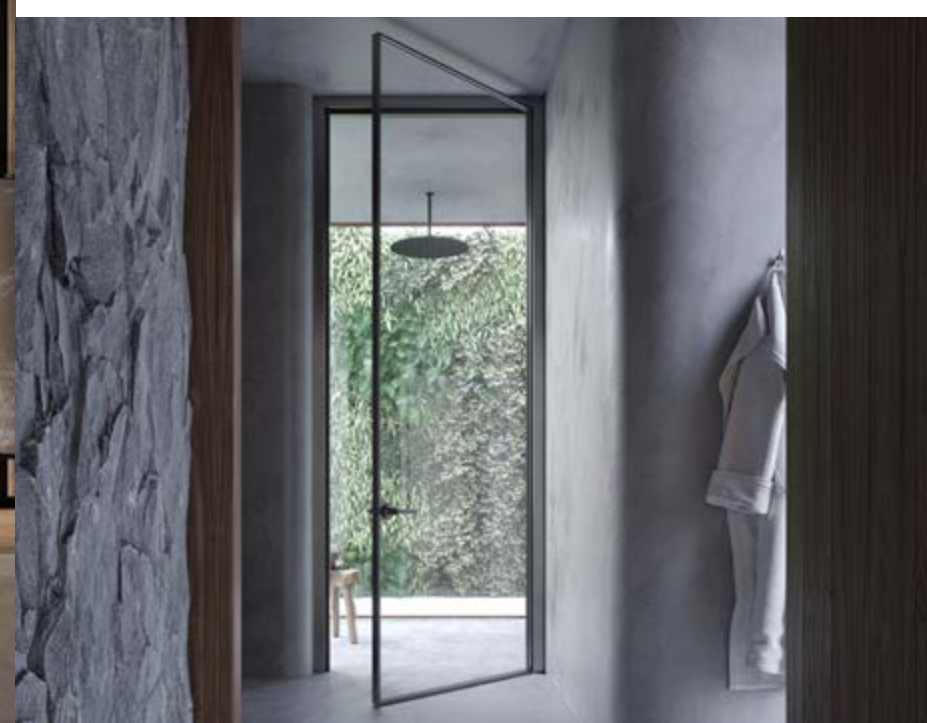





METRA S.p.A

Via Stacca 1,
25050 - Rodengo Saiano
Brescia - Italy
T +39 030 68191
F +39 030 6819990

info@metrabuilding.com

METRA RAGUSA S.p.A.

Zona industriale,
97100 - Ragusa
Italy
T +39 0932 660911
F +39 0932 667224

info.ragusa@metrabuilding.com

METRA ALUMINIUM INC.

2000, boul. Fortin
Laval, QC H7S 1P3
Canada
T (450) 629-4260
F (450) 629-4227

info.canada@metrabuilding.com

METRA USA

Waterford Business Park
5201 Blue Lagoon Drive, Unit #984
Miami, FL 33126
USA
T +1 305-915-0999

info.usa@metrabuilding.com



www.metrabuilding.com